



---

# **Microwave studies of chaotic systems**

## ***Lecture 3: A random matrix approach to fidelity***

Hans-Jürgen Stöckmann

stoeckmann@physik.uni-marburg.de

Fachbereich Physik, Philipps-Universität Marburg, Germany

# Contents

---



- Global perturbations
- Local perturbations
- Supersymmetries for pedestrians

---

# Global perturbations

# Definition of fidelity



Introduced by [Peres 1985](#) as a measure of the stability of quantum motion:

Perturbed Hamiltonian:  $H_\lambda = H_0 + \lambda V$

Time evolution of same initial state  $|\psi_0\rangle$  under  $H_0$  and  $H_\lambda$ :

$$|\psi_0(t)\rangle = e^{-2\pi i H_0 t} |\psi_0\rangle \quad |\psi_\lambda(t)\rangle = e^{-2\pi i H_\lambda t} |\psi_0\rangle$$

The **fidelity amplitude** is defined as the overlap integral

$$f_\lambda(t) = \langle \psi_0(t) | \psi_\lambda(t) \rangle$$

and the **fidelity** is  $F_\lambda(t) = |f_\lambda(t)|^2$ .

# The three regimes

---



- $\lambda \ll 1$ : perturbative regime

Gaussian decay

- $\lambda \approx 1$ : Fermi golden-rule regime

Exponential decay depending on the perturbation strength

- semiclassical approach (Cerrutti, Tomsovic 2002)
- random matrix approach (Gorin, Prosen, Seligman 2002)

- $\lambda \gg 1$ : Lyapunov regime

Exponential decay **independent** on the perturbation strength

- First observed in NMR spin-echo experiments (Zhang *et al.* 1992)
- explanation by Jalabert, Pastawski 2001

# Linear-response results



Linear-response result by Gorin, Prosen, Seligman 2004

$$f_\lambda(t) = 1 - 4\pi^2 \lambda^2 C(t)$$

where

$$C(t) = t^2 + \frac{t}{2} - \int_0^t \int_0^\tau b_2(t') dt' d\tau,$$

$b_2(t)$ : two-point form factor.

Exponentiated linear-response result, to extend validity:

$$f_\lambda(t) \sim e^{-4\pi^2 \lambda^2 C(t)}.$$

Describes fidelity decay both in the **perturbative** and the **Fermi golden rule** regime.

# Beyond linear response



Using **supersymmetry** techniques exact results are obtainable (Stöckmann, Schäfer 2004), yielding for the **GUE**

$$f_\epsilon(\tau) = \begin{cases} e^{-\frac{1}{2}\epsilon\tau} \left[ s\left(\frac{1}{2}\epsilon\tau^2\right) - \tau s'\left(\frac{1}{2}\epsilon\tau^2\right) \right], & \tau \leq 1 \\ e^{-\frac{1}{2}\epsilon\tau^2} \left[ s\left(\frac{1}{2}\epsilon\tau\right) - \frac{1}{\tau} s'\left(\frac{1}{2}\epsilon\tau\right) \right], & \tau > 1 \end{cases},$$

where

$$s(x) = \frac{\sinh(x)}{x}.$$

# Beyond linear response



Using **supersymmetry** techniques exact results are obtainable (Stöckmann, Schäfer 2004), yielding for the **GUE**

$$f_{\epsilon}(\tau) = \begin{cases} e^{-\frac{1}{2}\epsilon\tau} \left[ s\left(\frac{1}{2}\epsilon\tau^2\right) - \tau s'\left(\frac{1}{2}\epsilon\tau^2\right) \right], & \tau \leq 1 \\ e^{-\frac{1}{2}\epsilon\tau^2} \left[ s\left(\frac{1}{2}\epsilon\tau\right) - \frac{1}{\tau} s'\left(\frac{1}{2}\epsilon\tau\right) \right], & \tau > 1 \end{cases},$$

where

$$s(x) = \frac{\sinh(x)}{x}.$$

The corresponding calculation for the **GOE** yields

$$f_{\epsilon}(\tau) = 2 \int_{\text{Max}(0, \tau-1)}^{\tau} du \int_0^u \frac{v dv}{\sqrt{[u^2 - v^2][(u+1)^2 - v^2]}} \\ \times \frac{(\tau - u)(1 - \tau + u)}{(v^2 - \tau^2)^2} [(2u + 1)\tau - \tau^2 + v^2] e^{-\frac{1}{2}\epsilon[(2u+1)\tau - \tau^2 + v^2]}$$



# Comparison with linear response

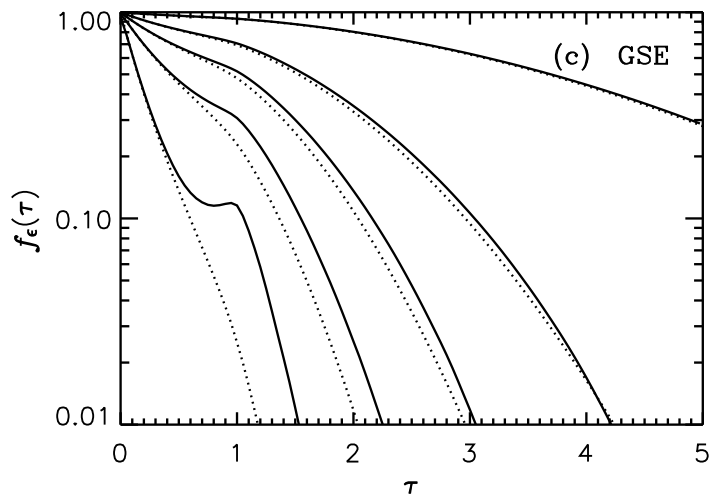
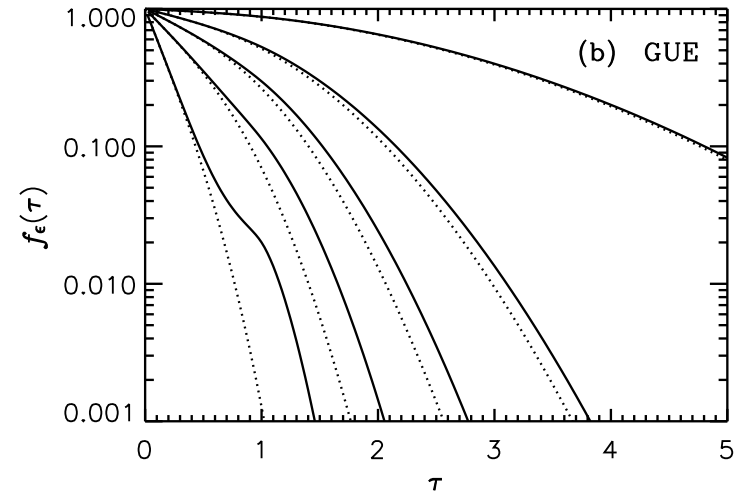
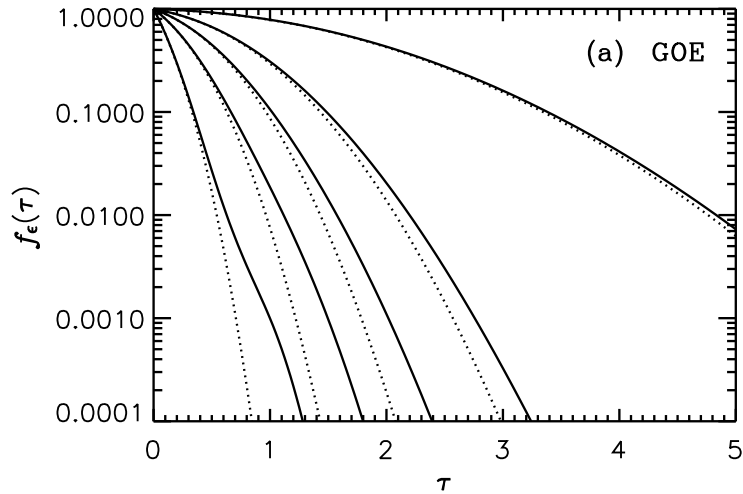

Perturbation strength:

$$\epsilon = 0.2, 1, 2, 4, 10.$$

Good agreement with linear-response result (dotted) for small  $\epsilon$  or for small times  $\tau$ .

(**GSE** results from numerics.)

# The fidelity recovery

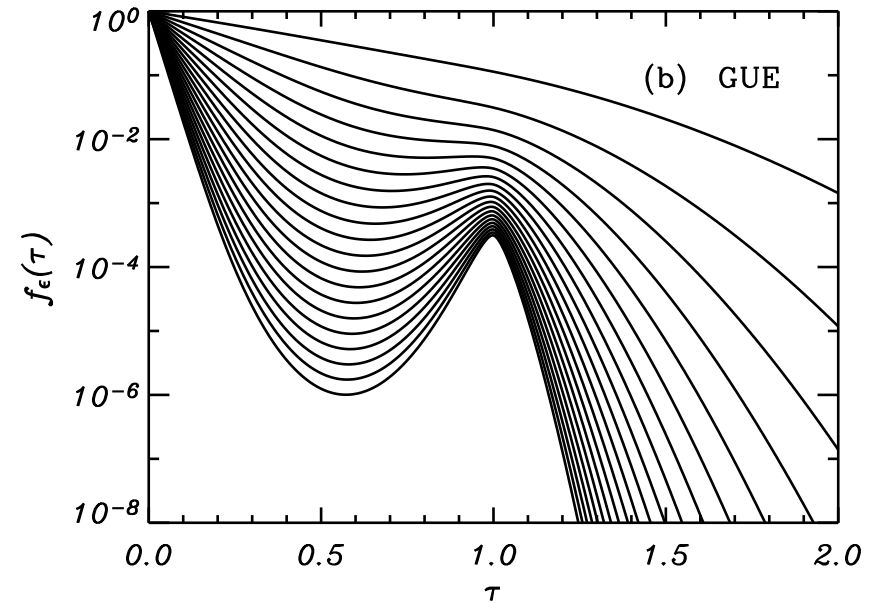
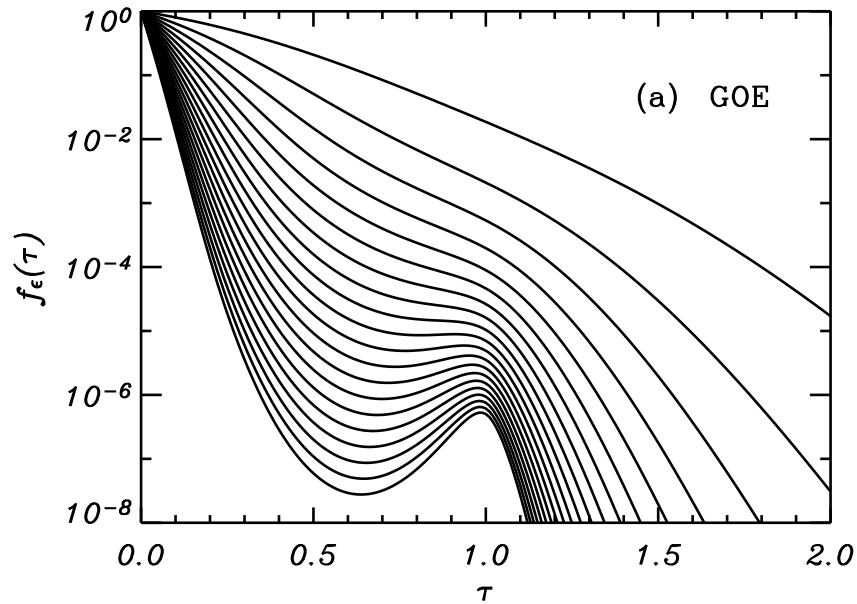

Fidelity amplitude  $f_\epsilon(\tau)$  for perturbation strengths  $\epsilon = 2, 4, \dots, 40$  for (a) the **GOE** and (b) the **GUE**.

# Microwave study of the fidelity



## Idea:

- Measure spatially resolved pulse-propagation  $\psi(\vec{r}, t)$   
(can be obtained from the Fourier transform of frequency spectra).
- Compute overlap of pulses for slightly different geometries

$$f_{\lambda}(t) = \int \psi(\vec{r}, t) \psi_{\lambda}^*(\vec{r}, t) d\vec{r}.$$

## Problem:

An antenna has to be scanned to measure the wave function  
 $\implies$  additional perturbation!

Fortunately, in **chaotic systems** things are much easier!

# Experimental setup

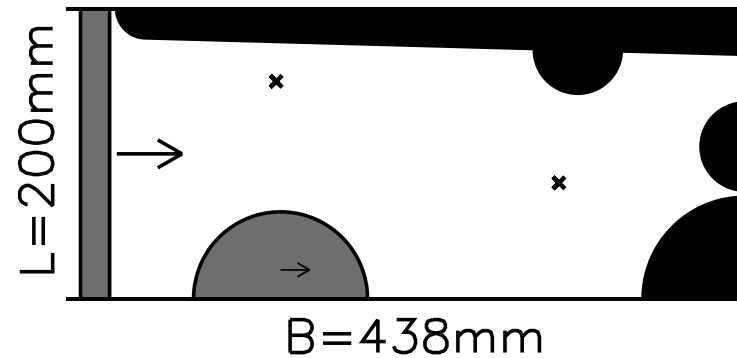
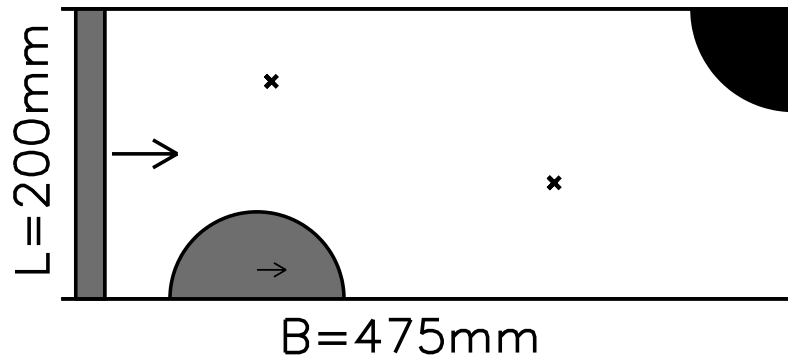

- Flat microwave resonators ( $\nu < c/2d$ ,  $d$ : height)
- Two antennas at fixed positions
- Left wall shifted in 10 steps of  $\Delta l = 0.2\text{mm}$ .
- Ensemble average by moving half-circle in 15 steps of  $2\text{cm}$ .
- Frequency range: from  $3$  to  $16\text{GHz}$  ( $\approx 500$  modes)

# The scattering fidelity



- Scattering matrix and effective Hamiltonian:

$$S_{ab}(E) = \delta_{ab} - V^{(a)\dagger} \frac{1}{E - H_{\text{eff}}} V^{(b)} \quad H_{\text{eff}} = H_{\text{int}} - (i/2) \sum_a V^{(a)} V^{(a)\dagger},$$

where  $V$  is the coupling matrix and  $V_{ja} \sim \psi_j(\vec{r}_a)$ .

# The scattering fidelity



- Scattering matrix and effective Hamiltonian:

$$S_{ab}(E) = \delta_{ab} - V^{(a)\dagger} \frac{1}{E - H_{\text{eff}}} V^{(b)} \quad H_{\text{eff}} = H_{\text{int}} - (\imath/2) \sum_a V^{(a)} V^{(a)\dagger},$$

where  $V$  is the coupling matrix and  $V_{ja} \sim \psi_j(\vec{r}_a)$ .

- Consider the Fourier transform of the correlation function

$$\hat{C}[S_{ab}, S_{ab}^{(\lambda)*}](t) = \left\langle \hat{S}_{ab}(t) \hat{S}_{ab}^{(\lambda)*}(-t) \right\rangle, \quad \hat{S}_{ab}(t) = \int dE e^{\frac{\imath}{\hbar} E t} S_{ab}(E).$$

- Reduces for  $\lambda = 0$  to auto-correlation function  $\hat{C}[S_{ab}, S_{ab}^*](t)$ .

# The scattering fidelity



- Scattering matrix and effective Hamiltonian:

$$S_{ab}(E) = \delta_{ab} - V^{(a)\dagger} \frac{1}{E - H_{\text{eff}}} V^{(b)} \quad H_{\text{eff}} = H_{\text{int}} - (\imath/2) \sum_a V^{(a)} V^{(a)\dagger},$$

where  $V$  is the coupling matrix and  $V_{ja} \sim \psi_j(\vec{r}_a)$ .

- Consider the Fourier transform of the correlation function

$$\hat{C}[S_{ab}, S_{ab}^{(\lambda)*}](t) = \left\langle \hat{S}_{ab}(t) \hat{S}_{ab}^{(\lambda)*}(-t) \right\rangle, \quad \hat{S}_{ab}(t) = \int dE e^{\frac{\imath}{\hbar} Et} S_{ab}(E).$$

- Reduces for  $\lambda = 0$  to auto-correlation function  $\hat{C}[S_{ab}, S_{ab}^*](t)$ .

- Define **scattering fidelity** via the relation:

$$\hat{C}[S_{ab}, S_{ab}^{(\lambda)*}](t) = f_{\lambda}^{\text{scat}}(t) \hat{C}[S_{ab}, S_{ab}^*](t)$$

- Reduces **in chaotic systems** for small perturbations to

$$f_{\lambda}^{\text{scat}}(t) = f_{\lambda}(t).$$

# Experimental fidelity amplitude

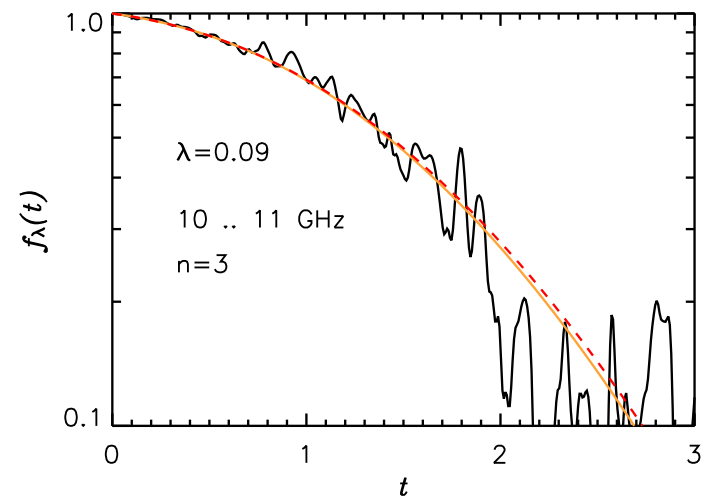
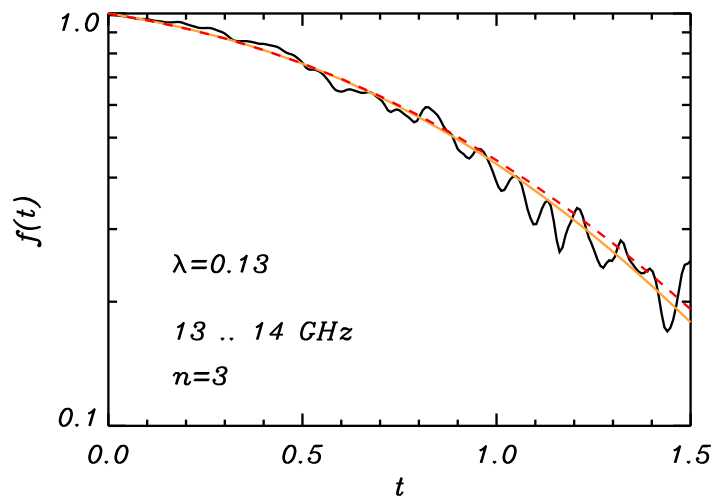
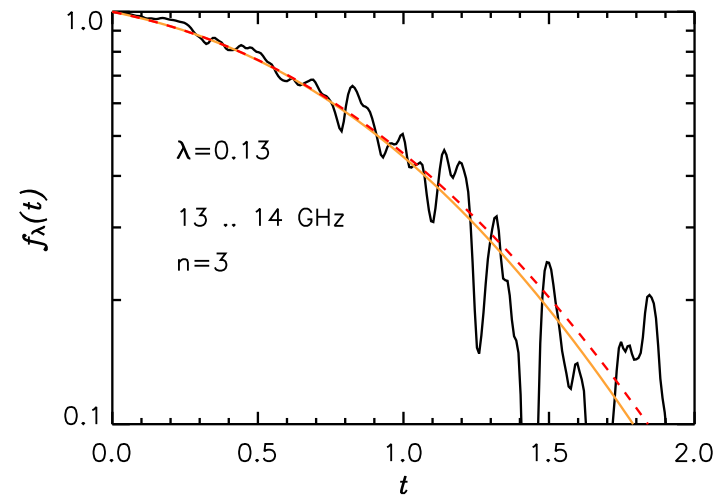
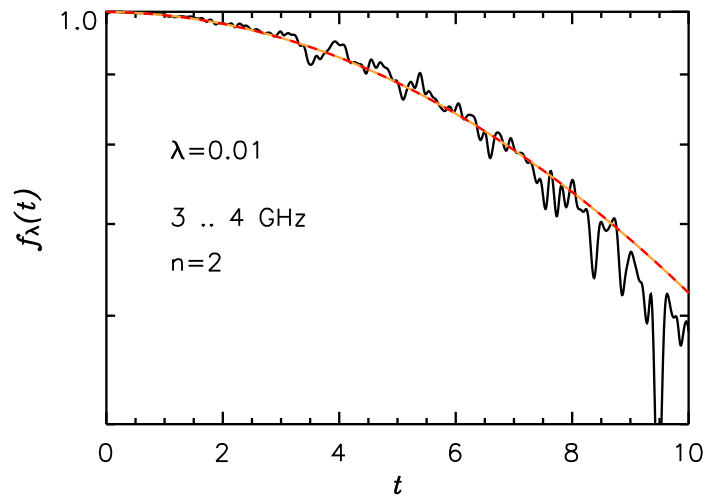

- - -: linear response approximation,

—: supersymmetry result



---

# Local perturbations

# Local fidelity studies

---



As before: Replace change of **Hamiltonian** by change of **shape**!

But there are two **alternatives**:

- **global** variation, e. g. by change of one **length**:  
wave functions are completely changed already for moderate variations ([Schäfer et al. 2005](#))
- **local** variation, e. g. by the change of a scatterer **position**:  
wave functions are changed only over a distance of some wave lengths

Previous **level dynamics** studies ([Barth et al. 1999](#)) suggest that there should be a qualitatively different behavior!

---

# Global versus local parameter variation

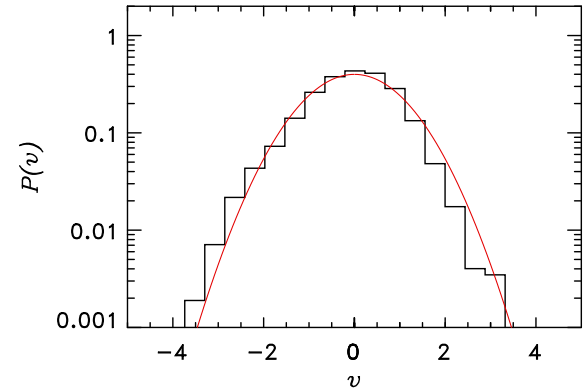
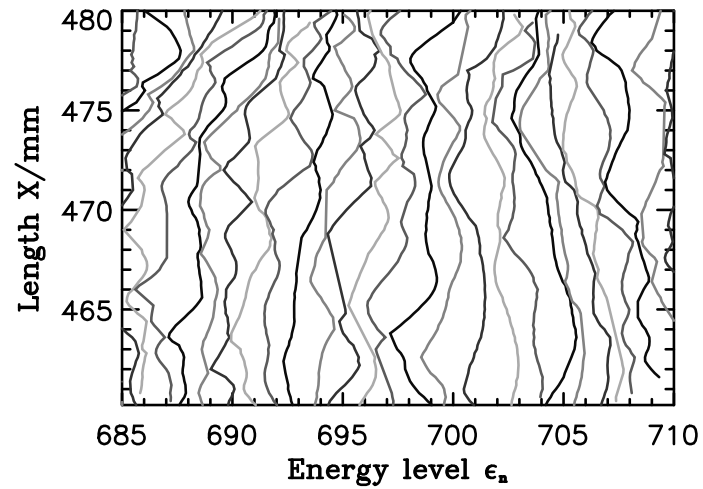
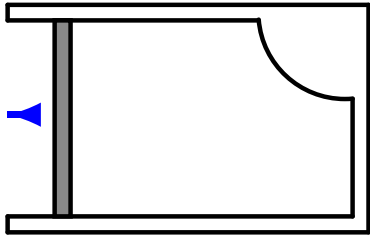

Global variation: Gaussian velocity distribution

# Global versus local parameter variation

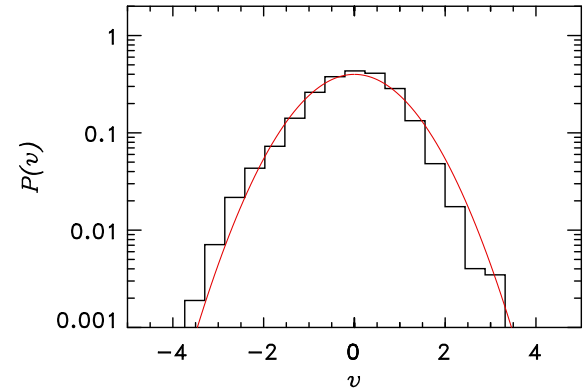
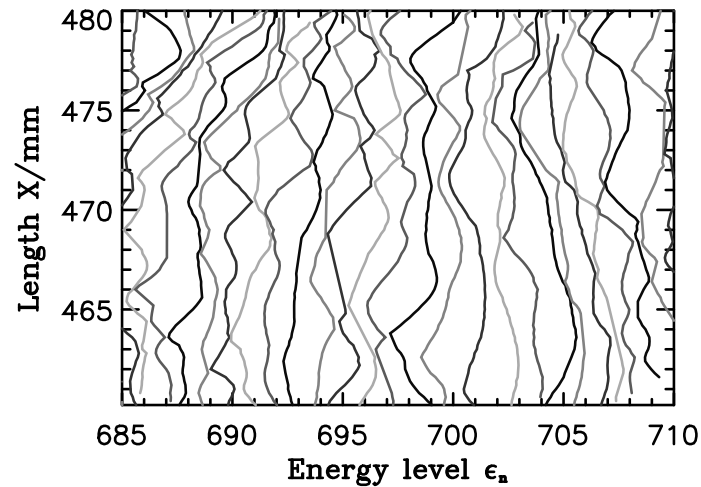
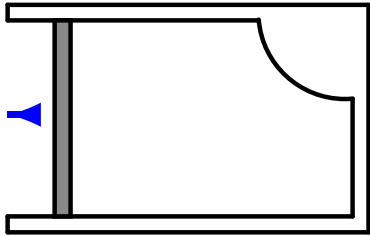

Global variation: **Gaussian** velocity distribution

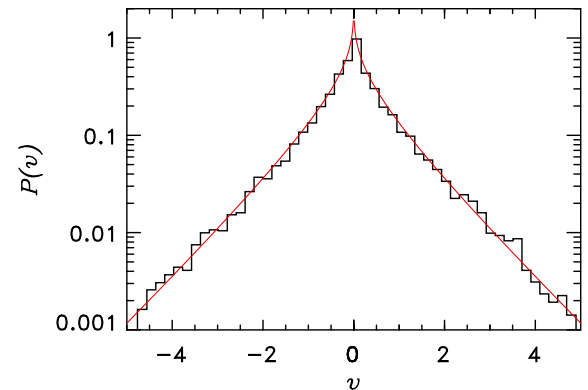
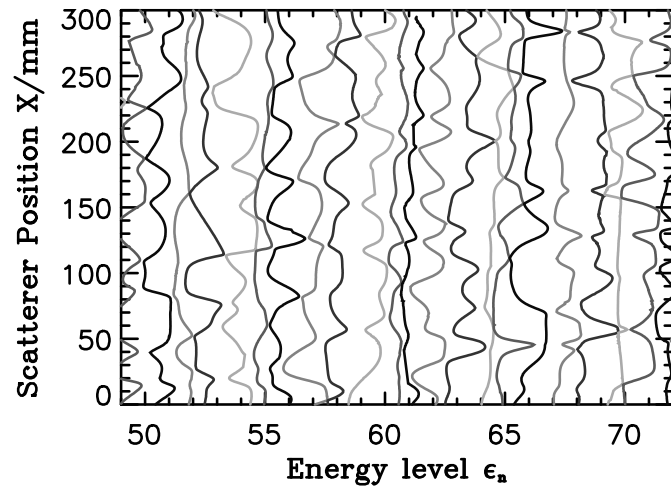
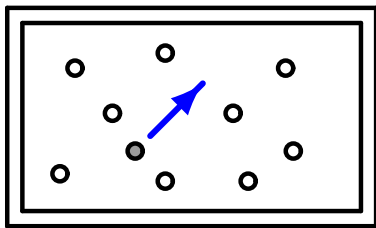

Local variation: **modified Bessel** velocity distribution

# Local perturbations

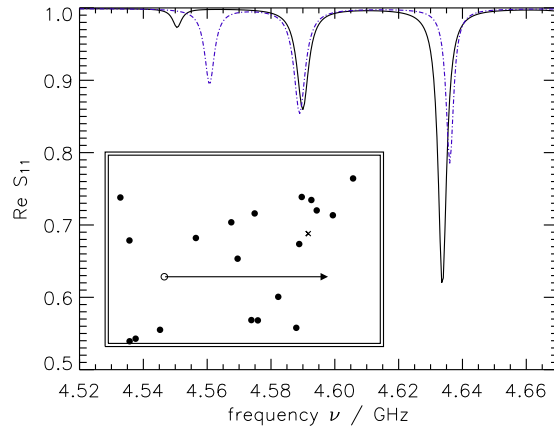

Scatterer shifts eigenenergies by

$$\Delta E_n \sim |\psi_n(r)|^2$$

$\psi_n(r)$ : wave function at the perturber position

It follows for the **Hamiltonian**

$$H_{nm}(r) = \delta_{nm}(E_n^0 + \alpha|\psi_n(r)|^2), \quad \alpha: \text{scatterer strength}$$

Valid for small shifts only! We never leave the perturbative regime  $\implies$

$$f(t) = \left\langle e^{2\pi i \alpha t (|\psi_1|^2 - |\psi_2|^2)} \right\rangle$$

$\psi_1, \psi_2$ : wave function before and after the shift

# The Gaussian average



Random plane wave assumption (Berry 1977) yields

$$f(t) = \frac{\sqrt{|K|}}{2\pi} \iint d\psi_1 d\psi_2 e^{2\pi i \alpha (|\psi_1|^2 - |\psi_2|^2)} e^{-\frac{1}{2}(\psi_1, \psi_2) K (\psi_1, \psi_2)^T}$$

where

$$K^{-1} = \begin{pmatrix} \langle \psi_1 \psi_1 \rangle & \langle \psi_1 \psi_2 \rangle \\ \langle \psi_2 \psi_1 \rangle & \langle \psi_2 \psi_2 \rangle \end{pmatrix} \quad \langle \psi_i \psi_j \rangle = \frac{1}{A} J_0(k|r_i - r_j|)$$

# The Gaussian average



Random plane wave assumption (Berry 1977) yields

$$f(t) = \frac{\sqrt{|K|}}{2\pi} \iint d\psi_1 d\psi_2 e^{2\pi i \alpha (|\psi_1|^2 - |\psi_2|^2)} e^{-\frac{1}{2}(\psi_1, \psi_2) K (\psi_1, \psi_2)^T}$$

where

$$K^{-1} = \begin{pmatrix} \langle \psi_1 \psi_1 \rangle & \langle \psi_1 \psi_2 \rangle \\ \langle \psi_2 \psi_1 \rangle & \langle \psi_2 \psi_2 \rangle \end{pmatrix} \quad \langle \psi_i \psi_j \rangle = \frac{1}{A} J_0(k|r_i - r_j|)$$

It follows

$$f(t) = [1 + (\lambda t)^2]^{-\frac{1}{2}} \quad \lambda = \frac{4\pi\alpha}{A} \sqrt{1 - J_0^2(k|\Delta r|)}$$

**Algebraic** long-time decay

$$f(t) \sim t^{-1}$$

# Results

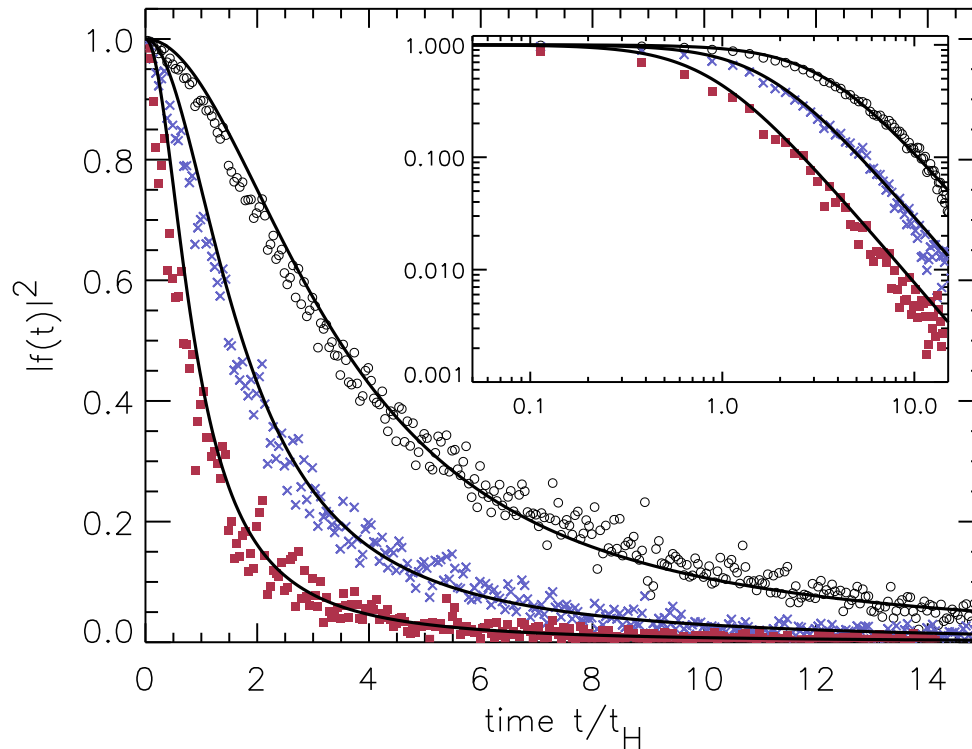

Fidelity decay for three different perturber shifts  
 $|\Delta r| = 1, 2, 4 \text{ mm}$

$$f(t) = [1 + (\lambda t)^2]^{-\frac{1}{2}}$$

$$\lambda = \frac{4\pi\alpha}{A} \sqrt{1 - J_0^2(k|\Delta r|)}$$

No fit applied!

The only free parameter  $\alpha$  has been taken from the variance of the level velocities.



# Scaling behavior

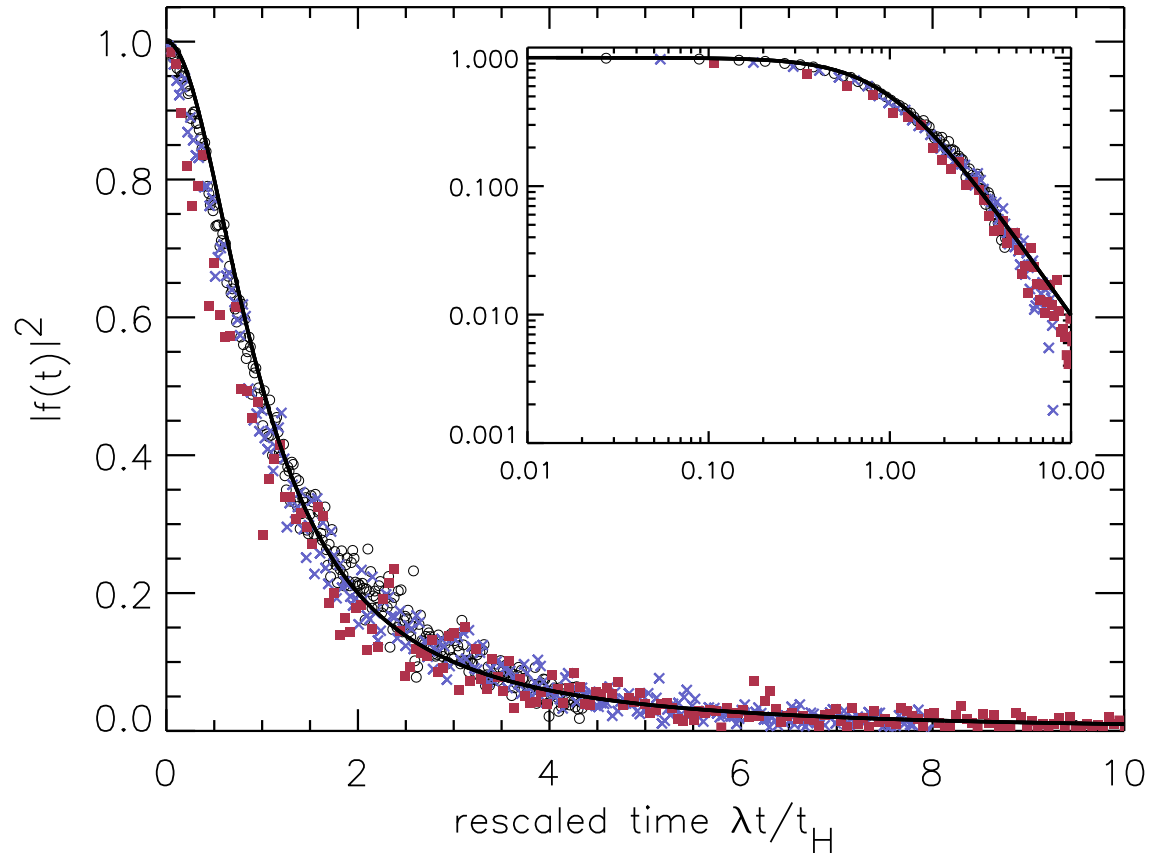

On a **rescaled** time axis  $\lambda t$  all curves coincide!

# Supersymmetries for pedestrians

Rewrite expression for **fidelity**

$$\begin{aligned} f_\lambda(\tau) &= \langle \psi_0 | e^{2\pi i H_0 \tau} e^{-2\pi i (H_0 + \lambda V) \tau} | \psi_0 \rangle \\ &= \frac{1}{N} \text{Tr} \left[ e^{2\pi i H_0 \tau} e^{-2\pi i (H_0 + \lambda V) \tau} \right] \end{aligned}$$

such that the dependencies on the matrix elements **factorize**.

Rewrite expression for **fidelity**

$$\begin{aligned} f_\lambda(\tau) &= \langle \psi_0 | e^{2\pi i H_0 \tau} e^{-2\pi i (H_0 + \lambda V) \tau} | \psi_0 \rangle \\ &= \frac{1}{N} \text{Tr} \left[ e^{2\pi i H_0 \tau} e^{-2\pi i (H_0 + \lambda V) \tau} \right] \end{aligned}$$

such that the dependencies on the matrix elements **factorize**.

1. Step:

Write the average of the fidelity amplitude as a Fourier transform,

$$\langle f_\lambda(\tau) \rangle = \int dE_1 dE_2 e^{2\pi i (E_1 - E_2) \tau} R_\lambda(E_1, E_2)$$

where

$$R_\lambda(E_1, E_2) \sim \frac{1}{N} \left\langle \text{Tr} \left( \frac{1}{E_{1+} - H_0 - \lambda V} \frac{1}{E_{2-} - H_0} \right) \right\rangle$$

# Idea (cont.)

---



## 2. Step:

Express  $A_{nm}^{-1}$ , where  $A = E_{1+} - H_0 - \lambda V$  or  $E_{2-} - H_0$  in terms of determinants

$$(A^{-1})_{nm} = \frac{1}{|A|} \frac{\partial |A|}{\partial A_{nm}}$$

# Idea (cont.)



## 2. Step:

Express  $A_{nm}^{-1}$ , where  $A = E_{1+} - H_0 - \lambda V$  or  $E_{2-} - H_0$  in terms of determinants

$$(A^{-1})_{nm} = \frac{1}{|A|} \frac{\partial |A|}{\partial A_{nm}}$$

## 3. Step:

Write  $|A|^{-1}$  as a Fresnel integral

$$\prod_i \left( \int dx_i^* dx_i \right) \exp \left( i \sum_{ij} x_i^* A_{ij} x_j \right) = \frac{(2\pi i)^N}{|A|} .$$

# Idea (cont.)



## 2. Step:

Express  $A_{nm}^{-1}$ , where  $A = E_{1+} - H_0 - \lambda V$  or  $E_{2-} - H_0$  in terms of determinants

$$(A^{-1})_{nm} = \frac{1}{|A|} \frac{\partial |A|}{\partial A_{nm}}$$

## 3. Step:

Write  $|A|^{-1}$  as a Fresnel integral

$$\prod_i \left( \int dx_i^* dx_i \right) \exp \left( i \sum_{ij} x_i^* A_{ij} x_j \right) = \frac{(2\pi i)^N}{|A|} .$$

But how to treat  $|A|$  ??

# Anticommuting variables

---



These are sets  $\{\xi_n\}$  obeying

$$\xi_i \xi_j + \xi_j \xi_i = 0.$$

Special case:  $\xi^2 = 0$ , i. e., functions of anticommuting variables are constant or linear!

Integrals over anticommuting variables are defined formally as

$$\int d\xi = 0, \quad \int \xi d\xi = \frac{1}{\sqrt{2\pi}}.$$



# Anticommuting variables



These are sets  $\{\xi_n\}$  obeying

$$\xi_i \xi_j + \xi_j \xi_i = 0.$$

Special case:  $\xi^2 = 0$ , i. e., functions of anticommuting variables are constant or linear!

Integrals over anticommuting variables are defined formally as

$$\int d\xi = 0, \quad \int \xi d\xi = \frac{1}{\sqrt{2\pi}}.$$

3. Step:

It follows

$$\prod_i \left( \int d\xi_i^* d\xi_i \right) \exp \left( \imath \sum_{ij} \xi_i^* A_{ij} \xi_j \right) = \frac{|A|}{(2\pi\imath)^N}.$$

# Supersymmetry



Collecting the results:

$$\prod_i \left( \int dx_i^* dx_i \right) \exp \left( i \sum_{ij} x_i^* A_{ij} x_j \right) = \frac{(2\pi i)^N}{|A|} .$$

$$\prod_i \left( \int d\xi_i^* d\xi_i \right) \exp \left( i \sum_{ij} \xi_i^* A_{ij} \xi_j \right) = \frac{|A|}{(2\pi i)^N} .$$

**Symmetric** in the commuting and the anticommuting variables!

# Supersymmetry



Collecting the results:

$$\prod_i \left( \int dx_i^* dx_i \right) \exp \left( \imath \sum_{ij} x_i^* A_{ij} x_j \right) = \frac{(2\pi\imath)^N}{|A|} .$$

$$\prod_i \left( \int d\xi_i^* d\xi_i \right) \exp \left( \imath \sum_{ij} \xi_i^* A_{ij} \xi_j \right) = \frac{|A|}{(2\pi\imath)^N} .$$

**Symmetric** in the commuting and the anticommuting variables!

This allows to express inverses of matrices in terms of **superintegrals**:

$$(A^{-1})_{ij} = \frac{1}{|A|} \frac{\partial |A|}{\partial A_{ji}} = \int d[x] \xi_j^* \xi_i \exp \left[ \imath \sum_{ij} (x_i^* A_{ij} x_j + \xi_i^* A_{ij} \xi_j) \right]$$

# The Gaussian average



Application to  $R_\lambda(E_1, E_2)$  yields

$$\begin{aligned} R_\lambda(E_1, E_2) &\sim \frac{1}{N} \left\langle \text{Tr} \left( \frac{1}{E_{1+} - H_0 - \lambda V} \frac{1}{E_{2-} - H_0} \right) \right\rangle \\ &= \frac{1}{N} \int d[x] d[y] \sum_{n,m} \xi_n^* \xi_m \eta_m^* \eta_n e^{-i[E_1 \mathbf{x}^\dagger \mathbf{x} - E_2 \mathbf{y}^\dagger \mathbf{y}]} \\ &\quad \times \left\langle e^{i[\mathbf{x}^\dagger \mathbf{H}_0 \mathbf{x} - \mathbf{y}^\dagger \mathbf{H}_0 \mathbf{y}]} \right\rangle \left\langle e^{i\lambda \mathbf{x}^\dagger \mathbf{V} \mathbf{x}} \right\rangle, \end{aligned}$$

where  $\mathbf{x} = (x_1, \xi_1, \dots, x_N, \xi_N)^T$ ,  $\mathbf{y} = (y_1, \eta_1, \dots, y_N, \eta_N)^T$ .

Now the Gaussian average over the matrix elements of  $H_0$  and  $H_1$  can be trivially performed!

# The Gaussian average



Application to  $R_\lambda(E_1, E_2)$  yields

$$\begin{aligned} R_\lambda(E_1, E_2) &\sim \frac{1}{N} \left\langle \text{Tr} \left( \frac{1}{E_{1+} - H_0 - \lambda V} \frac{1}{E_{2-} - H_0} \right) \right\rangle \\ &= \frac{1}{N} \int d[x] d[y] \sum_{n,m} \xi_n^* \xi_m \eta_m^* \eta_n e^{-i[E_1 \mathbf{x}^\dagger \mathbf{x} - E_2 \mathbf{y}^\dagger \mathbf{y}]} \\ &\quad \times \left\langle e^{i[\mathbf{x}^\dagger \mathbf{H}_0 \mathbf{x} - \mathbf{y}^\dagger \mathbf{H}_0 \mathbf{y}]} \right\rangle \left\langle e^{i\lambda \mathbf{x}^\dagger \mathbf{V} \mathbf{x}} \right\rangle, \end{aligned}$$

where  $\mathbf{x} = (x_1, \xi_1, \dots, x_N, \xi_N)^T$ ,  $\mathbf{y} = (y_1, \eta_1, \dots, y_N, \eta_N)^T$ .

Now the Gaussian average over the matrix elements of  $H_0$  and  $H_1$  can be trivially performed!

**However:** The calculation of the **superintegrals** is highly non-trivial!

# Summary

---



- **Supersymmetry** techniques yield exact result for **global** perturbations
- **Local** perturbations can be treated in terms of the **random plane wave** model
- For **global** perturbations there is a **Gaussian** or **exponential** long-time decay
- In contrast the fidelity decays algebraically  $\sim t^{-1}$  for **local** perturbations
- Most perturbations in real systems are short-ranged (e. g. diffusive **jumps** or mutual **spin-flips**)
- Possible (positive) implications for **quantum computing**

# Thanks!

---



## Coworkers:

U. Kuhl

R. Schäfer

R. Höhmann

## Cooperations:

T. Seligman, Cuernavaca, Mexico

T. Gorin, Dresden

T. Prosen, Ljubljana, Slovenia

H. Kohler, Heidelberg

The experiments have been supported by the **DFG** via the



FG 760 “Scattering Systems with Complex Dynamics”.

Talks: <http://www.physik.uni-marburg.de/qchaoszip/Maribor2008.zip>

Papers: <http://www.physik.uni-marburg.de/qchaos>